

# *Gas-Tr-Ex* Hazardous Area Transmitters Launch

**“Renfrew 19 November 2009 ”**



Gas Measurement Instruments Ltd



*Detection, Protection, Innovation*

- To highlight the features and benefits of the *GasTrEx* range
- To provide the technical background to the product
- To give a detailed summary of the products' selling points
- To provide examples of the markets for the products

- A fully ATEX approved 4 ~20 mA transmitter
- Suitable for all environments
- Full display, together with non-intrusive one man calibration
- Full range of inter-connectivity to third party systems



- An exciting new range of transmitter sensors for Hazardous areas

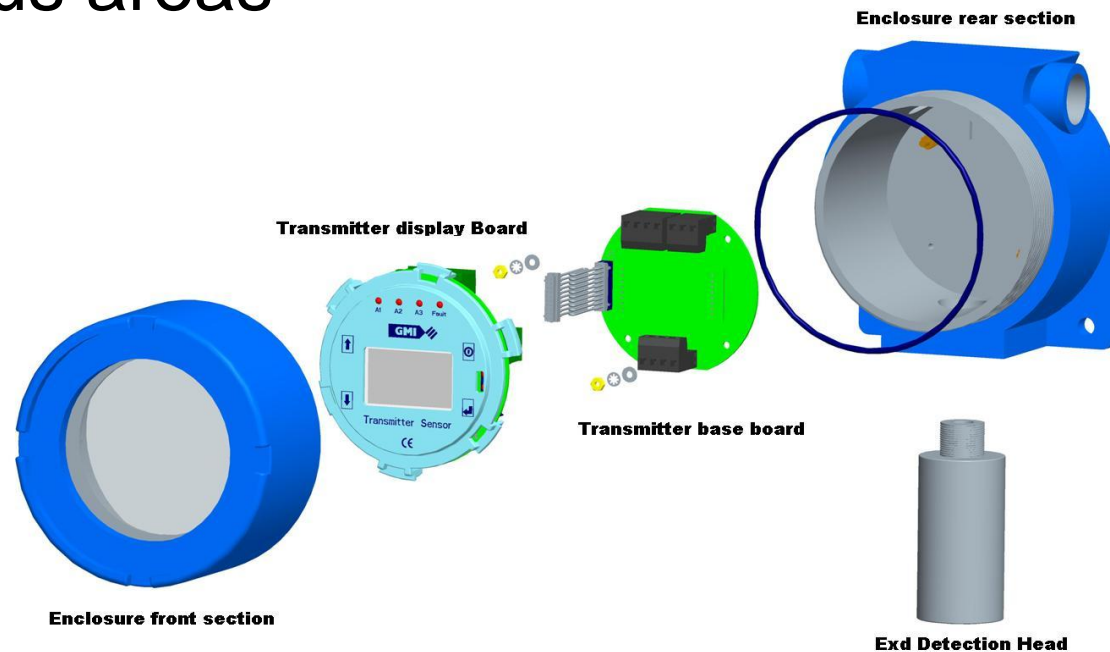

# Product description

GasTrEx

High Quality Flame-proof enclosure  
Ex d IIc T6  
Epoxy coated Aluminium or  
Electroplated Stainless Steel  
Tempered glass display version or  
Blind version

**Enclosure rear section**

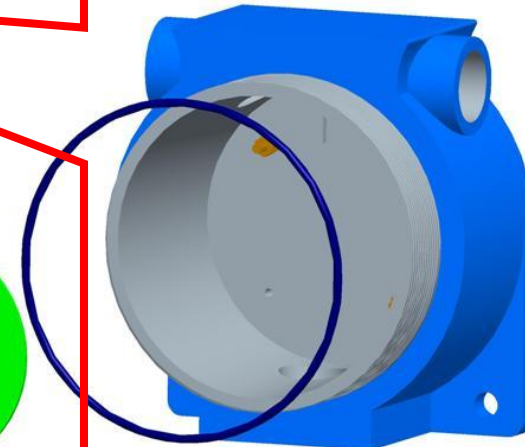

**Transmitter display Board**

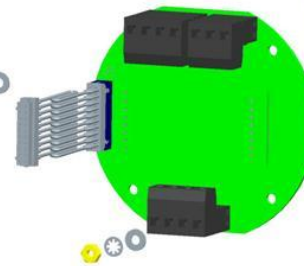

**Transmitter base board**



**Enclosure front section**



**Exd Detection Head**

Gas Measurement Instruments Ltd



Detection, Protection, Innovation

# Product description

GasTrEx

## Transmitter Base Board

Sensor input, conditioning,  
amplify and initial calibrate  
Power supply input, 4~20 mA  
o/p Fault relay o/p

## Transmitter display Board



Enclosure front section

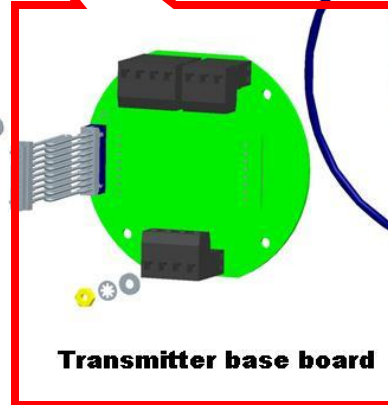

Transmitter base board

## Enclosure rear section

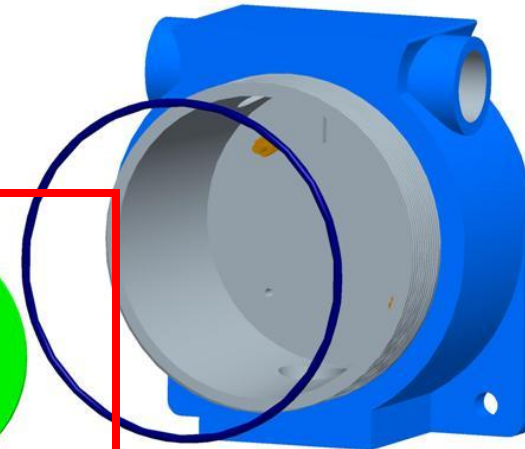

Exd Detection Head



Gas Measurement Instruments Ltd



Detection, Protection, Innovation

# Product description

GasTrEx

Transmitter Display Board  
LCD Display  
Alarm LEDs and V.F. relay o/ps  
Non Intrusive Calibration  
Magnetic Wand

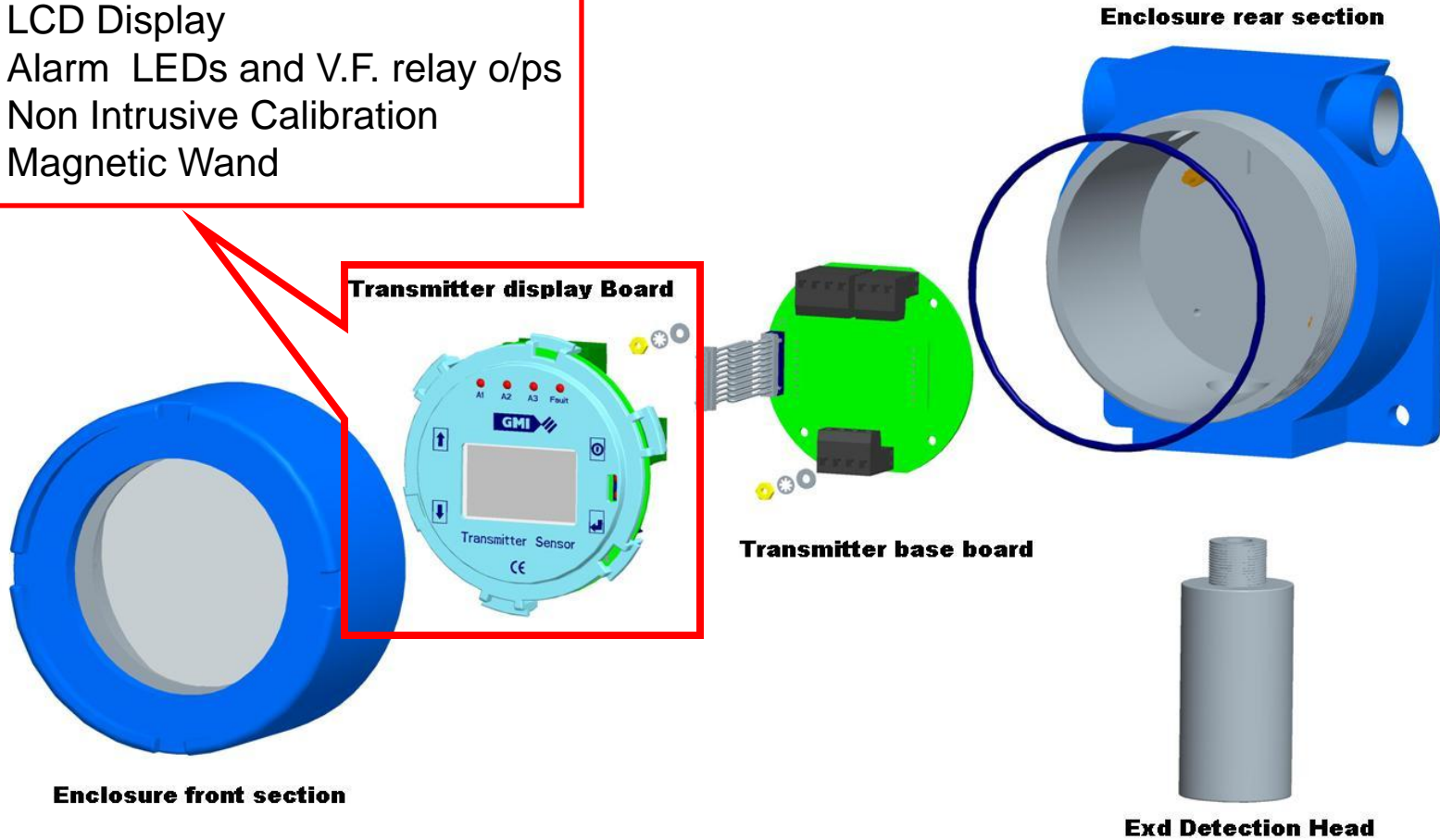

Gas Measurement Instruments Ltd



Detection, Protection, Innovation



# Product description

GasTrEx

Transmitter Display Board  
LCD Display  
Alarm LEDs and V.F. relay o/ps  
Non Intrusive Calibration  
Magnetic Wand

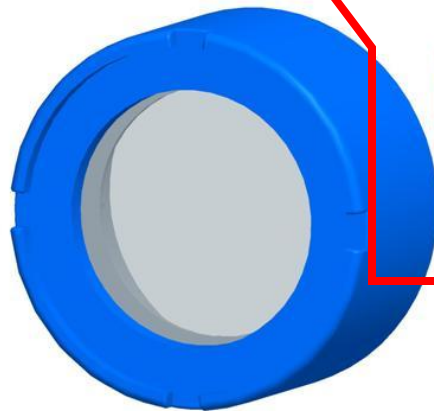

Enclosure front section

Transmitter display Board

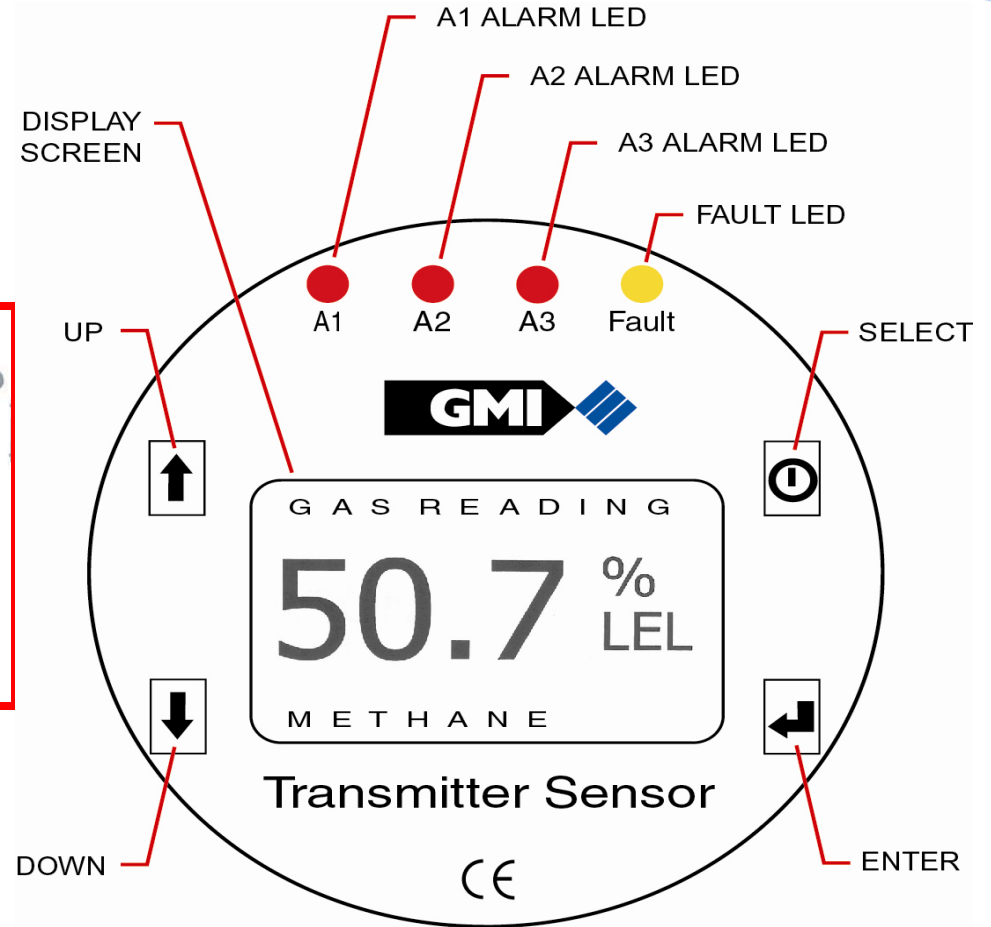



# Product description

GasTrEx

## Exd Detection Head

Flammable - Catalytic, I.R.  
Toxic - Electrochemical  
CO2 - I.R.

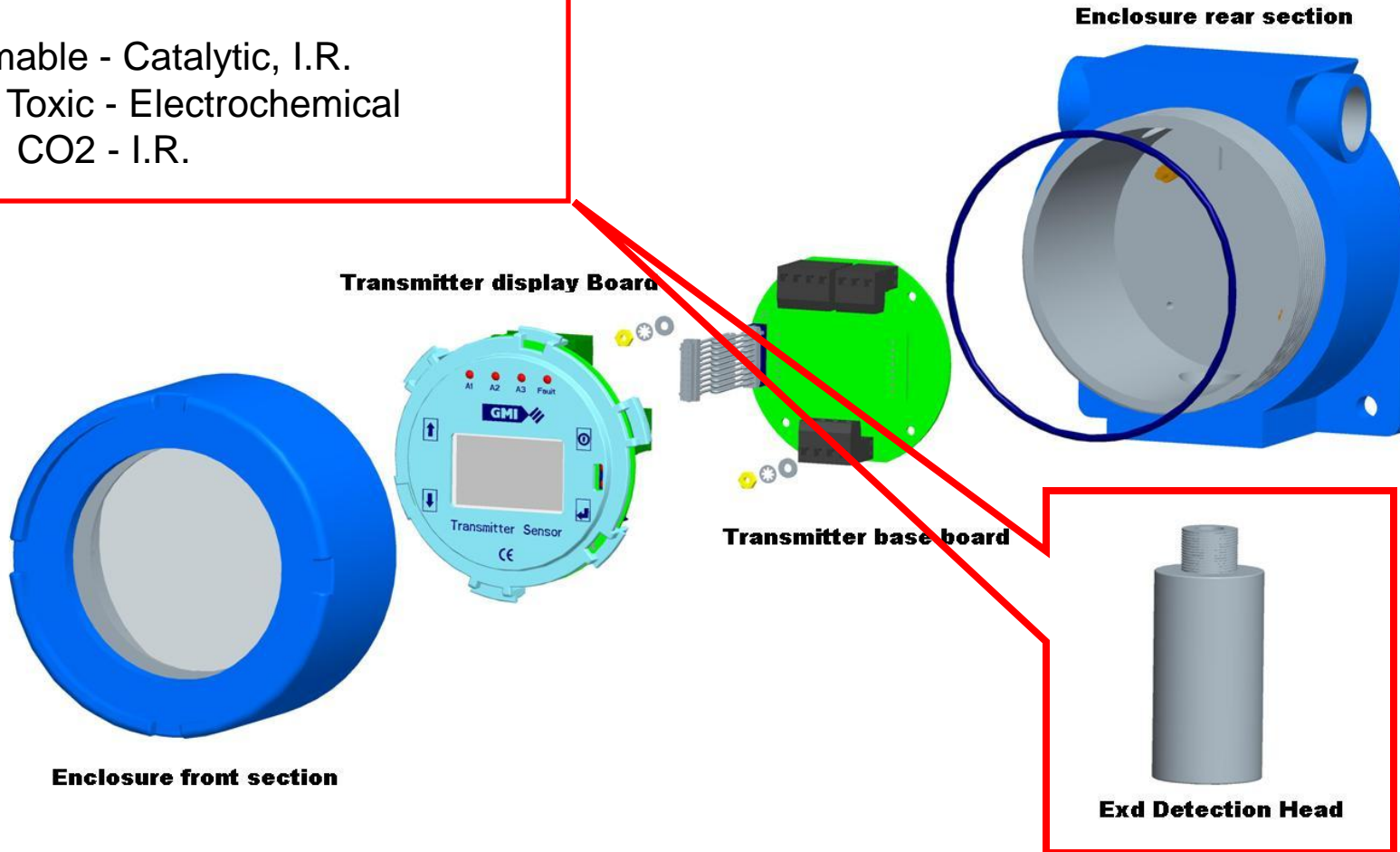

Gas Measurement Instruments Ltd



Detection, Protection, Innovation

- Available in marine grade aluminum or St/St
- Choice of display or non-display versions
- suitable for the detection of flammable or toxic gases

- Toxic gases include H<sub>2</sub>S, CO, CO<sub>2</sub> and oxygen deficiency
- Flammable detection by either IR or catalytic sensor
- Other gases will be available over the next year
- VOC and Freon detection can be made available if necessary

- Universal transmitter which can be configured for any gas sensor by use of plug-in personality module

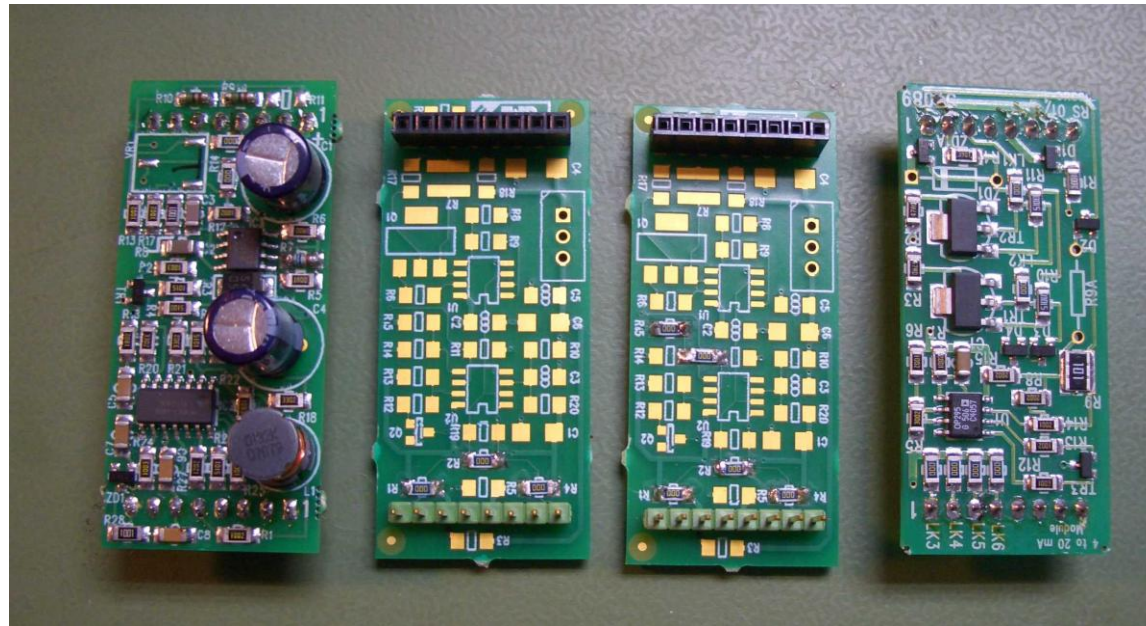

- Sink or source 4 ~ 20 mA output with full electrical isolation as standard (non isolated version optional)

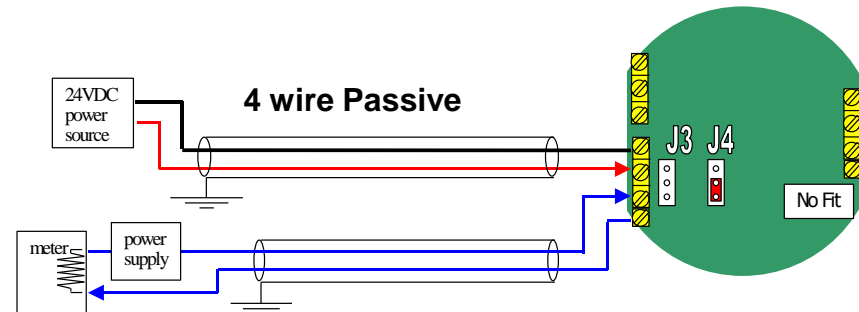
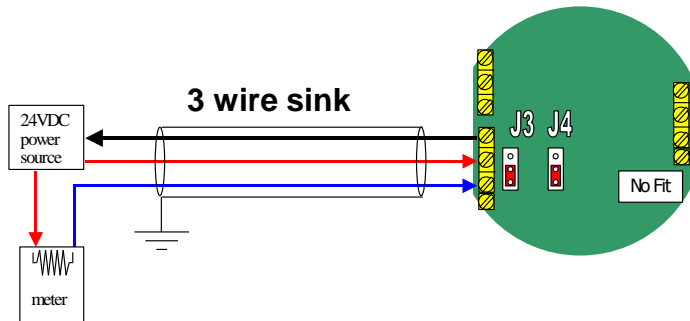
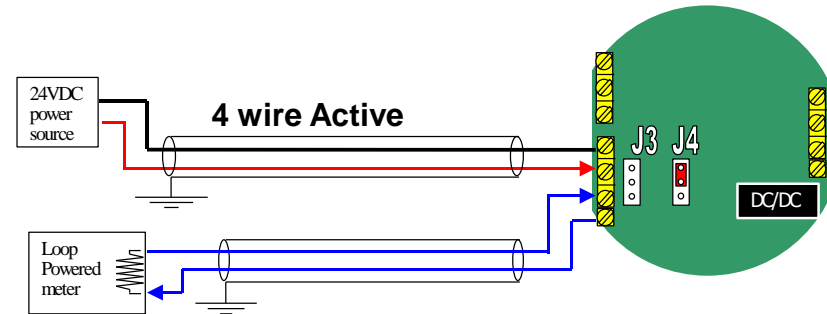
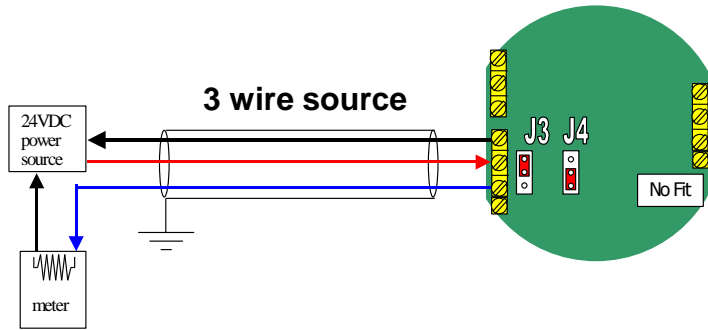

- Simple plug in connection terminals for easy installation
- Lower cost non display version available for price sensitive applications

- Detailed descriptions of most of the suitable applications are in the application note section
- Applications not covered in application notes include
- Petrochem, where the sheer variety makes it impossible to cover in one note
- These products will be suitable for 99% of petrochem applications for flammable and H<sub>2</sub>S monitoring



- These products are designed to meet the requirements of the most demanding customers
- Typical markets include Chemical Plants, Refineries, Onshore and Offshore installations
- Additional markets include Water Treatment, Power Generation, Tunneling and Construction
- Shipping vessels and terminals

- Very cost effective complete product range compared to the market leaders
- Universal transmitter for all applications reducing stocking requirements
- The universal nature allows end users to reduce spare holdings
- Flexible output options for maximum interconnectivity

- Reduced maintenance costs, one man calibration
- Very easy to install with the plug-in connectors
- Range of options and prices dependant upon application from non-display aluminium enclosures to full display St/St versions
- Extensively tested, derivative technology proven in GMI portables therefore low risk purchase

- Product is manufactured in-house under the complete Q.A. control of GMI at every stage
- GMI are fully approved to the latest ISO 9000:2009 standard
- GMI are the largest British independent manufacturer of gas detection Est. 1947
- GMI the world leader in instruments for the gas industry with world-wide support network

- What experience does GMI have in supplying fixed systems

GMI have supplied fixed systems for many years and supplied systems to offshore installations in the boom years, 1980's in the North Sea. Recently GMI have specialized in niche markets such as, Landfill developments, defense establishments, brewing, power generation and the general construction Industry among others.

- Are the units fully compliant with the European standards
  - Absolutely, these products meet all relevant standards
- Do the units meet MED and US standards
  - Not yet, However all the products have been submitted to UL and certification is expected first half of next year. MED is in a similar state

- Can these units be connected to any other system  
Absolutely, the flexible output configuration allows the GMI GasTrEx to connect to all 4-20mA input devices
- Is the transmitter fully isolated from the power supply  
Yes, there is an isolator on the PCB which allows the unit be connected to a third party device powered separately



- How can we be sure that these new products are reliable?

These products have been extensively tested on beta test sites over the last few months with no problems. Generally this is repackaged technology for GMI which has had extensive field exposure over the last 10 years

- What are the unique selling features of these products

These are premium products for a wide range of gases and comparable with Draeger / MSA / Honeywell / Crowcon at a very competitive price and are ideally suited for system builders

- What happens when we come across a large very competitive project  
    Contact GMI support personnel who will try to help you out with expertise both technical and commercial.

- This is a state of the art product at a very competitive price
- The built-in flexibility enables the product to meet every need
- The product is customer friendly and designed to meet their “needs and wants”
- GMI is the high quality “low cost” “low risk” solution to a customers gas transmitter requirements